

ACCELERATION AND PAIRS OF FORCES

A. In Figure 1, the student pushes the desk starting from rest. The student reaches a speed of 3 m/s in 2 s. In Figure 2, the students together push the desk from rest to a speed of 6 m/s in 2 s. In each case, find the acceleration of the desk and the force applied to it. Fill answers in the spaces provided.

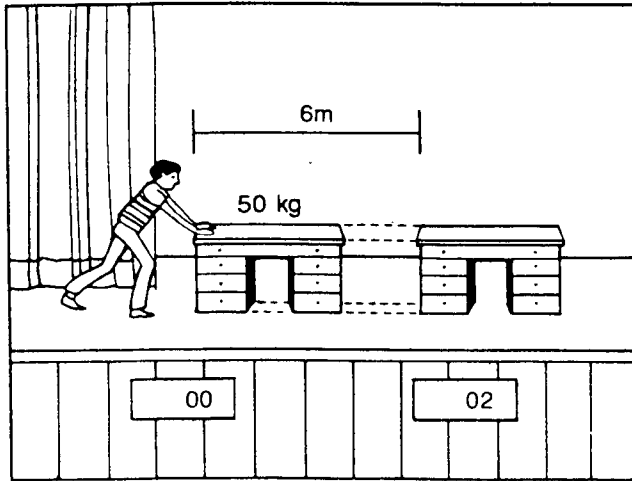

Figure 1.

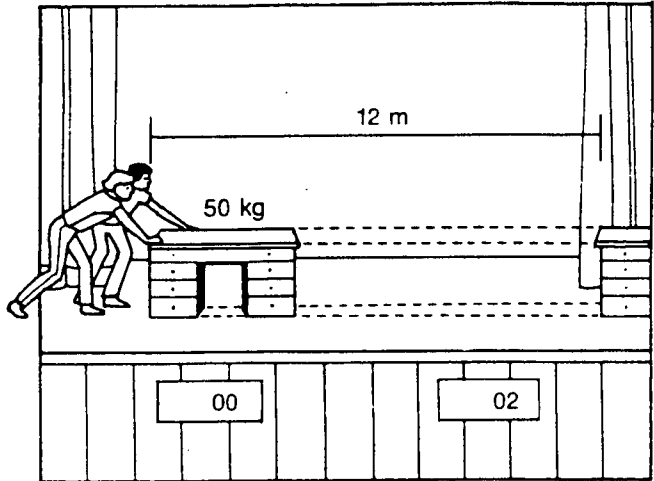

Figure 2.

Acceleration = _____ m/s–0 m/s
 _____ s
 = _____ m/s/s

Force = $m \times a$
 = 50 kg x _____ m/s/s
 = _____ N

Acceleration = _____ m/s–0 m/s
 _____ s
 = _____ m/s/s

Force = $m \times a$
 = 50 kg x _____ m/s/s
 = _____ N

B. Forces always act in pairs. Describe the pairs of forces in the pictures above. _____
